

VC-GPON-OLT-B

GPON OLT 1490nm/1310nm Class B+ SFP Transceiver

Features

- ✓ Single fiber bi-directional data links asymmetric TX 2488Mbps/RX1244Mbps application
- ✓ 1490nm continuous-mode DFB laser transmitter and 1310nm burst-mode APD-TIA receiver
- ✓ Small Form Factor Pluggable package with SC/UPC Connector
- ✓ Support Class B+ 17~32dB attenuation range application (With FEC)
- ✓ Reset burst-mode receiver design support more than 15dB dynamic range
- ✓ 0 to 70°C operating case temperature
- ✓ Single 3.3V power supply
- ✓ Digital diagnostic monitoring interface
- ✓ Digital burst RSSI function to monitor the input optical power level
- ✓ LVPECL compatible data input/output interface
- ✓ LVTTL transmitter disable control
- ✓ LVTTL transmitter laser fault alarm
- ✓ LVTTL receiver Signal Detect (SD) indication response within 50ns.
- ✓ Low EMI and excellent ESD protection
- ✓ Class I laser safety standard IEC-60825 compliant
- ✓ RoHS-6 compliance



Applications

- ✓ Gigabit-capable Passive Optical Networks (GPON) Class B+ 20Km 17~32dB attenuation range

Standards

- ✓ Complies with SFP Multi-Source Agreement (MSA) SFF-8074i
- ✓ Complies with SFF-8472 Rev 9.5
- ✓ Complies with ITU-T G.984.2 Amendment 2
- ✓ Complies with FCC 47 CFR Part 15, Class B
- ✓ Complies with FDA 21 CFR 1040.10 and 1040.11

Absolute Maximum Ratings

Table 1 - Absolute Maximum Ratings

Parameter	Symbol	Min	Max	Unit	Note
Storage Ambient Temperature	T _{STG}	-40	85	°C	
Operating Case Temperature	T _c	0	70	°C	
Operating Humidity	OH	5	95	%	
Power Supply Voltage	V _{cc}	0	3.6	V	
Receiver Damaged Threshold		+4		dBm	

Recommended Operating Environment

Table 2 - Recommended Operating Environment

Parameter	Symbol	Min	Typical	Max	Unit	Notes
Power Supply Voltage	V _{cc}	3.13	3.3	3.47	V	
Operating Case Temperature	T _c	0		70	°C	
Operating Humidity Range	OH	5		95	%	
Data Rate			Tx 2488.32 Rx 1244.16		Mbit/s	

Transmitter Optical Characteristics

Table 3- Transmitter Optical Characteristics

Parameter	Symbol	Min	Typical	Max	Unit	Notes
Optical Center Wavelength	λ_c	1480		1500	nm	
Optical Spectrum Width (-20dB)	$\Delta\lambda$			1	nm	
Side Mode Suppression Ratio	SMSR	30			dB	
Average Launch Optical Power	AOP	+2.5		+5	dBm	BOL, Room Temperature

		+1.5		+5	dBm	EOL 0~70°C
Power-OFF Transmitter Optical Power				-39	dBm	Launched into SMF
Extinction Ratio	ER	8.2			dB	PRBS 2 ²³ -1+72CID @2.488Gbit/s
Tolerance to Transmitter Incident Light		-15			dB	
Transmitter Reflectance				-10	dB	
Transmitter and Dispersion Penalty	TDP			1	dB	Transmit on 20km SMF
Optical Waveform Diagram	ITU-T G.984.2					See the figure below

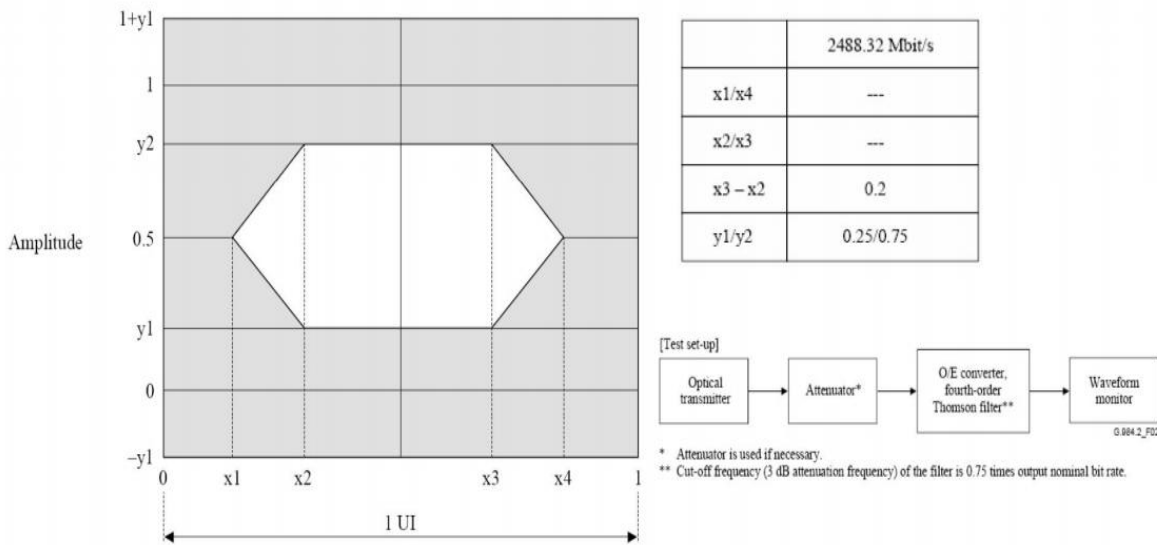

Transmitter Eye Mask Definitions and Test Procedure

Transmitter Electrical Characteristics

Table 4- Transmitter Electrical Characteristics

Parameter	Symbol	Min	Typical	Max	Unit	Notes
Data Input Differential Swing		200		1600	mV	LVPECL input, AC coupled
Input Differential Impedance		90	100	110	Ω	
Power Supply Current				220	mA	Load free
Transmitter Disable Voltage - Low		0		0.8	V	
Transmitter Disable Voltage - High		2.0		V _{CC}	V	
Transmitter Fault Alarm Voltage - Low		0		0.4	V	
Transmitter Fault Alarm Voltage - High		2.4		V _{CC}	V	

Receiver Optical Characteristics

Table 5- Receiver Optical Characteristics

Parameter	Symbol	Min	Typical	Max	Unit	Notes
Operating Wavelength		1260		1360	nm	
Sensitivity	SEN			-28	dBm	PRBS 2 ²³ -1+72CID@1 244Mbps BER $\leq 1 \times 10^{-10}$
Saturation Optical Power	SAT	-8			dBm	
Dynamic Range		15			dB	See the figure below
Signal Detect Assert Level				-30	dBm	
Signal Detect De-Assert Level		-45			dBm	
Signal Detect Hysteresis		0.5		6	dB	
Receiver Reflectance				-12	dB	

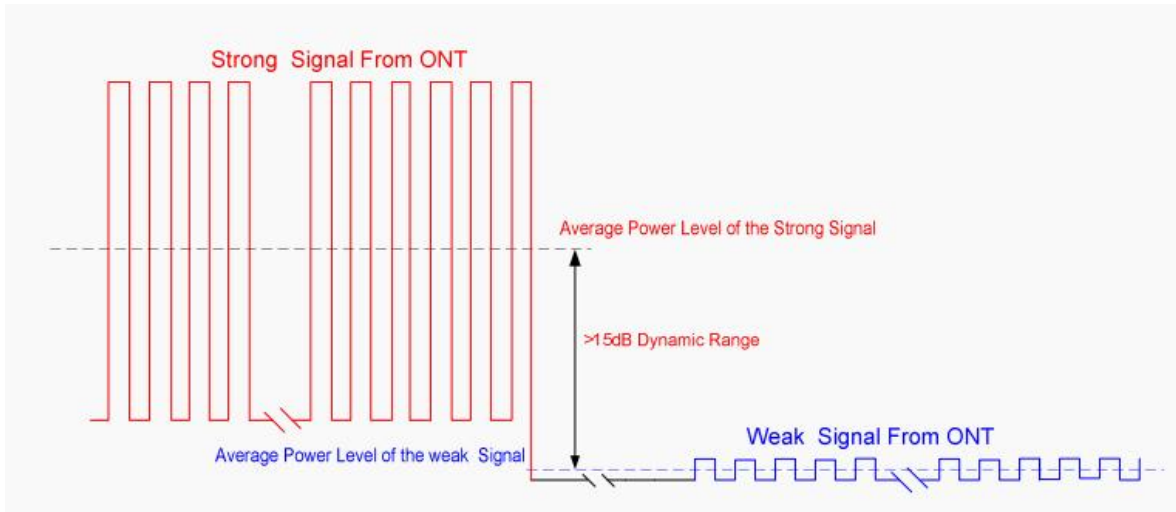

Burst Mode Receiver Dynamic Range in GPON System

Receiver Electrical Characteristics

Table 6- Receiver Electrical Characteristics

Parameter	Symbol	Min	Typical	Max	Unit	Notes
Power Supply Current				350	mA	Load free
Data Output Voltage – Low (-Vcc)		-1.81		-1.62	V	
Data Output Voltage – High (-Vcc)		-1.02		-0.88	V	
Data Output Differential Swing		400		1600	mV	LVPECL output, DC coupled
Reset width	T _{RESET}	16			bits	
Reset-Low		0		0.4	V	
Reset-High		2.4		Vcc	V	
Receiver Amplitude Recovery Time	T _{RECOVER Y}			32	bits	Refer to the Reset signal falling edge
Signal Detect Assert Time				50	ns	
Signal Detect De-				12.8	ns	Refer to the

assert Time						Reset signal rising edge
Signal Detect Voltage-Low		0		0.4	V	
Signal Detect Voltage-High		2.4		Vcc	V	
RSSI Trigger-Low		0		0.8	V	
RSSI Trigger-High		2.0		Vcc	V	
RSSI Trigger width	T _w	350	375	400	ns	
RSSI Trigger Delay	T _D		500		ns	Refer to first bit of the preamble
Optical Signal During Time	TONT EN_DUR R EN_DUR		2600		ns	TONT EN_DUR ≥ TD + TW For RSSI Measurement
I2C Access Prohibited Time		100		500	μs	
RX Power Monitor Range		-30		-8	dBm	Note 1

Note: RSSI result is provided by access to EEPROM A2H 104~105Byte the unit is 0.1uW.

Digital Diagnostic Monitoring

Table 7- Digital Diagnostic Monitoring

Parameter	Range	Accuracy	Calibration	Note
Temperature	0 to +70 °C	±3°C	Internal	1LSB = 1/256°C
Voltage	3.0 to 3.7 V	±3%	Internal	1LSB = 0.1mV
Bias Current	0 to 100 mA	±10%	Internal	1LSB = 2uA
TX Power	1.5 to 5 dBm	±2dB	Internal	1LSB = 0.1uW
RX Power Monitor	-30 to -8 dBm	±3dB	External	1LSB = 0.1uW

Note: The digital diagnostic monitoring interface defines 256-byte memory map in EEPROM, which makes use of the 8 bit address 1010001X(A2h).

Timing Parameter Definitions in Burst More Sequence

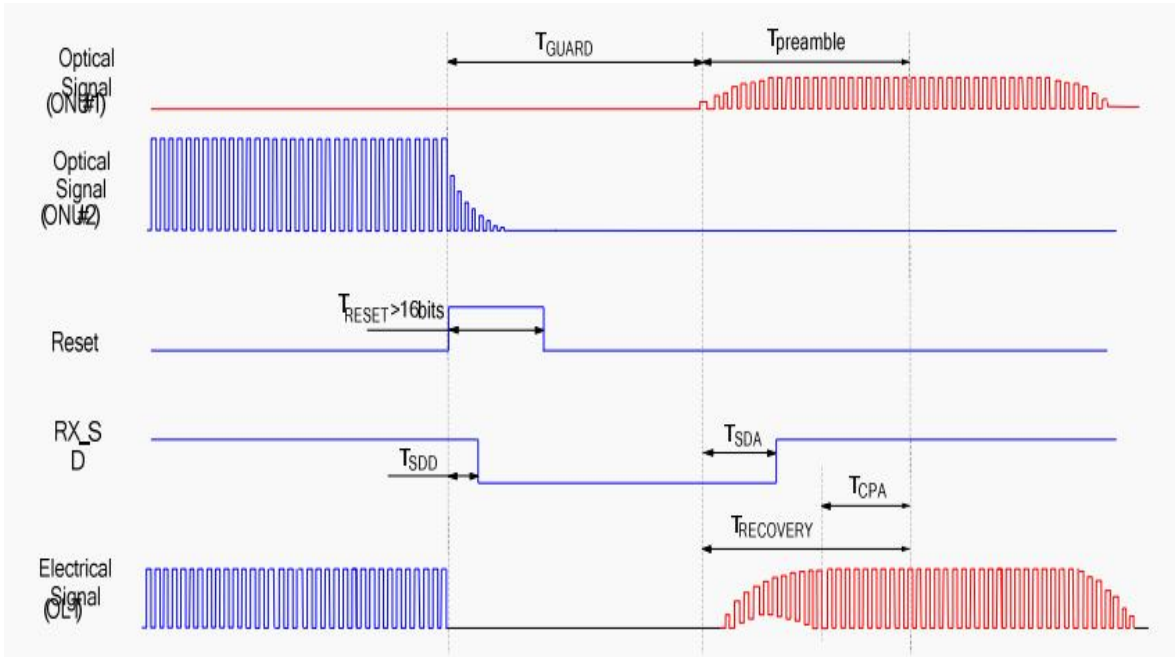

RSSI Timing Sequence

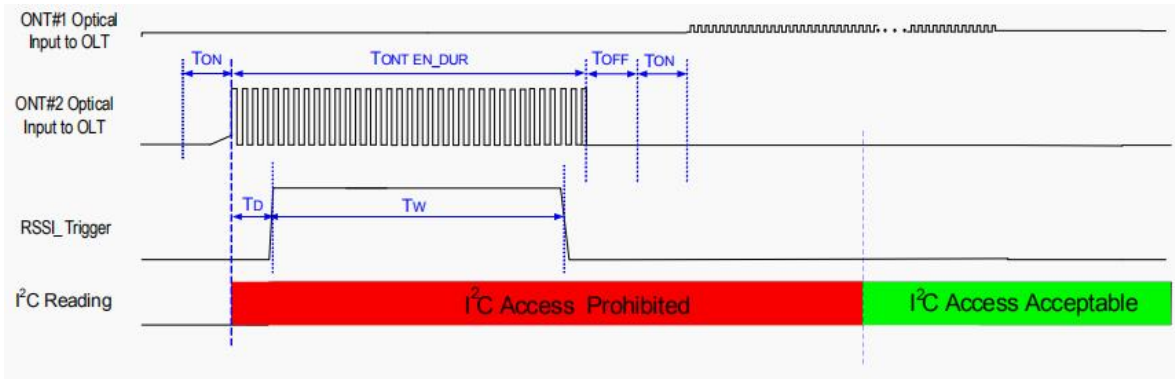

SFP Pin (Golden Finger) Drawing

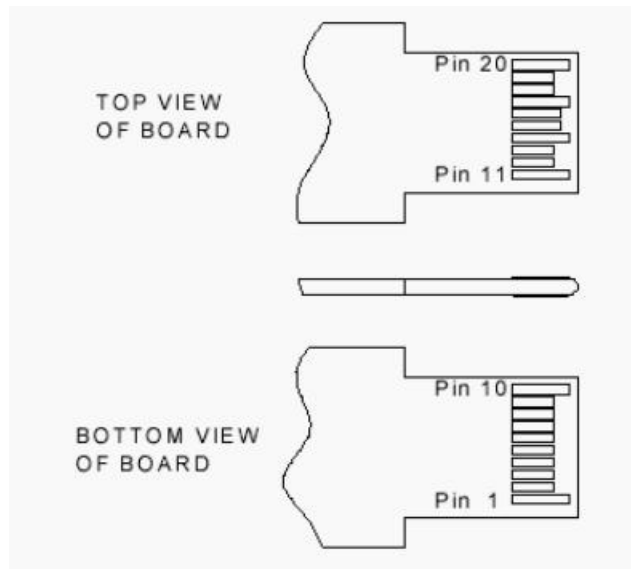

Pin Descriptions

Table 8- Pin Descriptions

Pin	Name	Description	Note
1	V _{EE} T	Transmitter Ground	
2	TX Fault	Transmitter Fault Indication	High: abnormal; Low:
3	TX Disable	Transmitter Disable	High: transmitter disable; Low: transmitter enable
4	MOD-DEF2	Module Definition 2	The data line of two wire serial interface
5	MOD-DEF1	Module Definition 1	The clock line of two wire serial interface
6	MOD-DEF0	Module Definition 0	Connected to Ground in the transceiver
7	Reset	Receiver Reset	High: reset the receiver
8	SD	Signal Detect	High: signal detected; Low:
9	RSSI Trigger	RSSI Trigger for Transceiver	High: enable RSSI A/D
10	V _{EE} R	Receiver Ground	
11	V _{EE} R	Receiver Ground	
12	RD-	Inv. Receiver Data Out	LVPECL logic output, DC coupled
13	RD+	Receiver Data Out	LVPECL logic output, DC coupled
14	V _{EE} R	Receiver Ground	
15	V _{CC} R	Receiver Power	
16	V _{CC} T	Transmitter Power	
17	V _{EE} T	Transmitter Ground	
18	TD+	Transmit Data In	LVPECL logic input, AC coupled
19	TD-	Inv. Transmit Data In	LVPECL logic input, AC coupled
20	V _{EE} T	Transmitter Ground	

SFP Recommended Host Board Power Supply Filtering Network

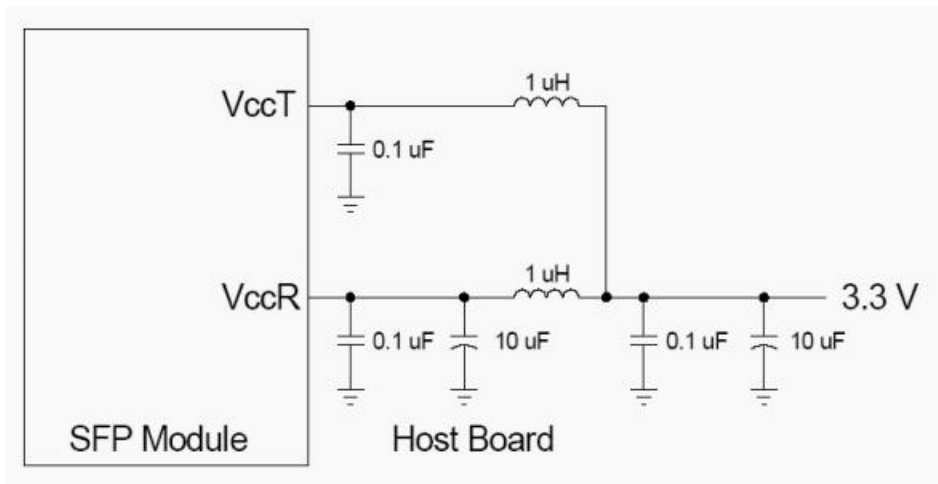

Typical Interface Circuit

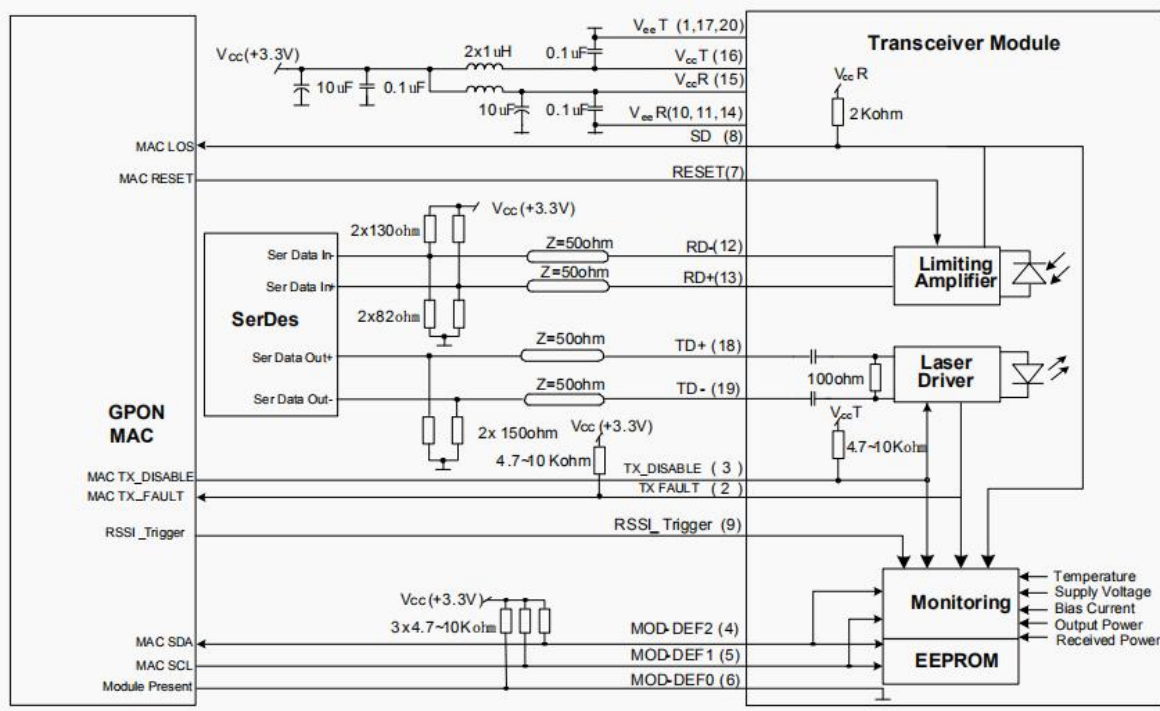

EEPROM Information

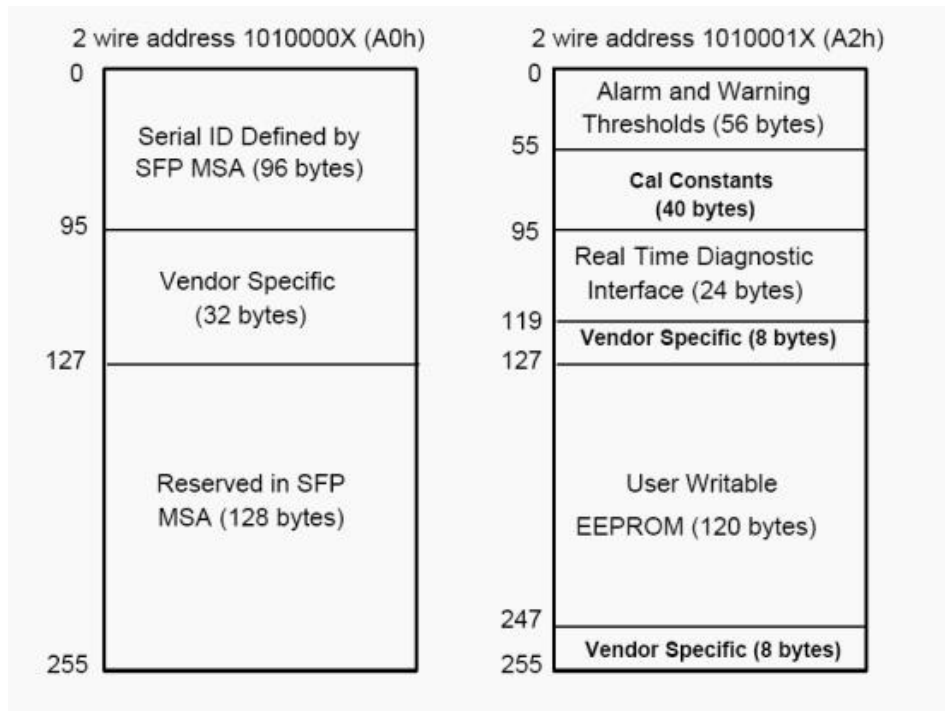

Mechanical Specifications

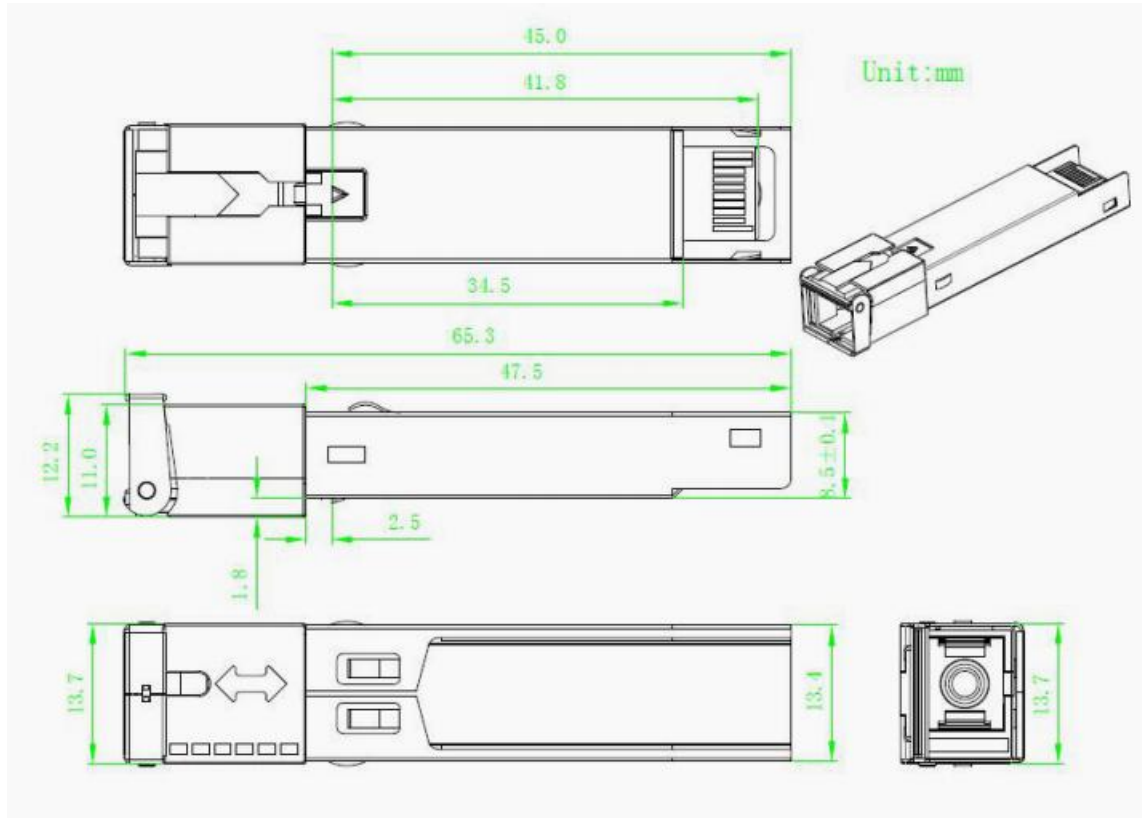

Ordering information

Table 9- Ordering information

Part Number	Product Description
VC-GPON-OLT-B	Tx 2488./Rx 1244., GPON OLT SFP Tx1490nm/ Rx1310nm SC Class B+, 0 ~ +70°C, with DDM