

VC-GPON-OLT-C+++

Features

- ✓ Single fiber bi-directional data links asymmetric TX 2488Mbps / RX1244Mbps application
- ✓ 1490nm continuous-mode DFB laser transmitter and 1310nm burst-mode APD-TIA receiver
- ✓ Small Form Factor Pluggable package with SC/UPC Connector
- ✓ Reset burst-mode receiver design support more than 15dB dynamic range
- ✓ 0 to 70°C operating temperature
- ✓ Single 3.3V power supply
- ✓ Digital diagnostic monitoring interface
- ✓ Digital burst RSSI function to monitor the input optical power level
- ✓ LVPECL compatible data input/output interface
- ✓ LVTTTL transmitter disable control
- ✓ LVTTTL transmitter laser fault alarm
- ✓ LVTTTL receiver Signal Detect
- ✓ Low EMI and excellent ESD protection
- ✓ Class I laser safety standard IEC-60825 compliant
- ✓ RoHS-6 compliance



Applications

- ✓ Gigabit-capable Passive Optical Networks (GPON) Class D 20Km

Absolute Maximum Ratings

Table 1 - Absolute Maximum Ratings

Standards

- ✓ Complies with SFP Multi-Source Agreement (MSA) SFF-8074i
- ✓ Complies with SFF-8472 Rev 9.5
- ✓ Complies with ITU-T G.984.2 Amendment 2

✓ Complies with FCC 47 CFR Part 15, Class B

Parameter	Symbol	Min.	Max.	Unit	Notes
Storage Ambient Temperature	TSTG	-40	85	°C	
Operating Case Temperature	Tc	0	70	°C	
Storage Humidity	OHs	5	95	%	
Power Supply Voltage	VCC	0	3.6	V	
Receiver Damaged Threshold		+5		dBm	

✓ Complies with FDA 21 CFR 1040.10 and 1040.11

Recommended Operating Environment

Table 2 - Recommended Operating Environment

Parameter	Symbol	Min.	Typ.	Max.	Unit	Notes
Power Supply Voltage	VCC	3.13	3.3	3.47	V	
Power Supply Current			350	500	mA	
Operating Case Temperature	Tc	0		70	°C	
Operating Humidity Range	OHo	5		85	%	
Nominal Data Rate			RX 1244.16 TX 2488.32		Mbit/s	

Transmitter Optical Characteristics

Table 3- Transmitter Optical Characteristics

Parameter	Symbol	Min.	Typ.	Max.	Unit	Notes
Optical Center Wavelength		1480		1500	nm	
Optical Spectrum Width (-20dB)	$\Delta\lambda$			1	nm	
Side Mode Suppression Ratio	SMSR	30			dB	
Average Launch Optical	AOP	+6		+10	dBm	EOL, 0~70°C

Power						
Power-OFF Transmitter Optical Power				-39	dBm	Launched into SMF
Extinction Ratio	ER	8.2			dB	PRBS 2 ²³ - 1+72CID @2.488Gbit/s
Tolerance to Transmitter Incident Light		- 15			dB	
Transmitter Reflectance				- 10	dB	
Transmitter and Dispersion Penalty	TDP			1	dB	Transmit on 20km SMF
Optical Waveform Diagram	ITU-T G.984.2					Figure 1,margin>5%

Transmitter Electrical Characteristics

Table 4- Transmitter Electrical Characteristics

Parameter	Symbol	Min.	Typ.	Max.	Unit	Notes
Data Input Differential Swing		600		1600	mV	LVPECL input, AC coupled
Input Differential Impedance		90	100	110	Q	
Transmitter Disable Voltage - Low		0		0.8	V	
Transmitter Disable Voltage - High		2.0		VCC	V	
Transmitter Fault Alarm Voltage - Low		0		0.4	V	
Transmitter Fault Alarm Voltage – High		2.4		Vcc	V	

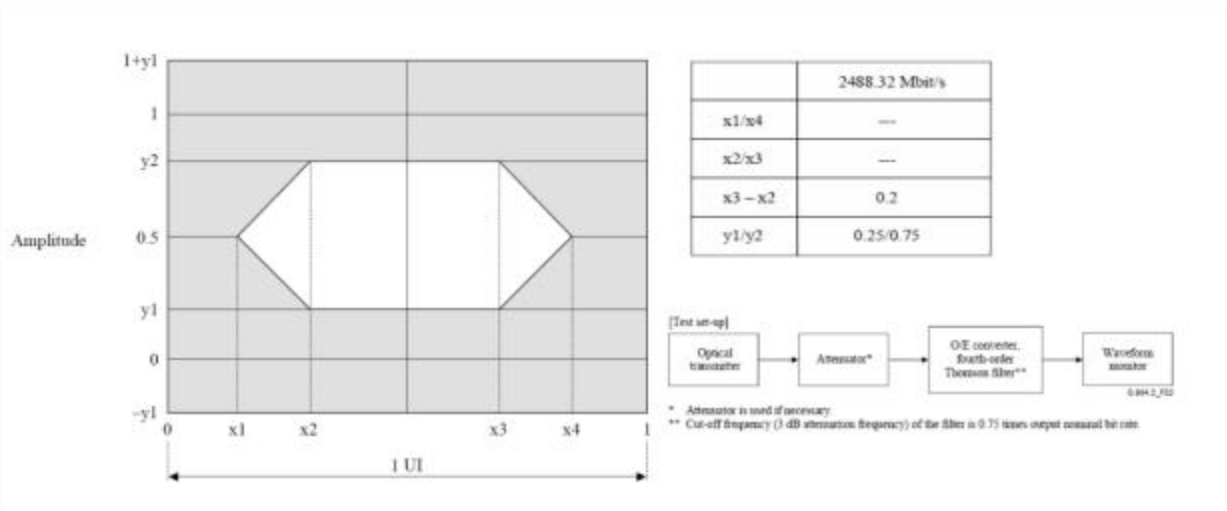

Figure 1 Transmitter Eye Mask Definitions and Test Procedure

Receiver Optical Characteristics

Table 5- Receiver Optical Characteristics

Parameter	Symbol	Min	Typ.	Max	Unit	Notes
Operating Wavelength	SEN	1290		1330	nm	
Sensitivity (EOL, 0~70°C)				-35	dBm	PRBS2 ²³ - 1+72CID@1.244Gbps BER ≤1×10 ⁻⁴ , ER≥10dB
Saturation Optical Power					dBm	
Dynamic Range		15			dB	Figure 2
SD Signal Assert Level				-36	dBm	
SD Signal De-assert Level		-45			dBm	
Hysteresis		0.5		6	dB	
Receiver Reflectance				12	dB	

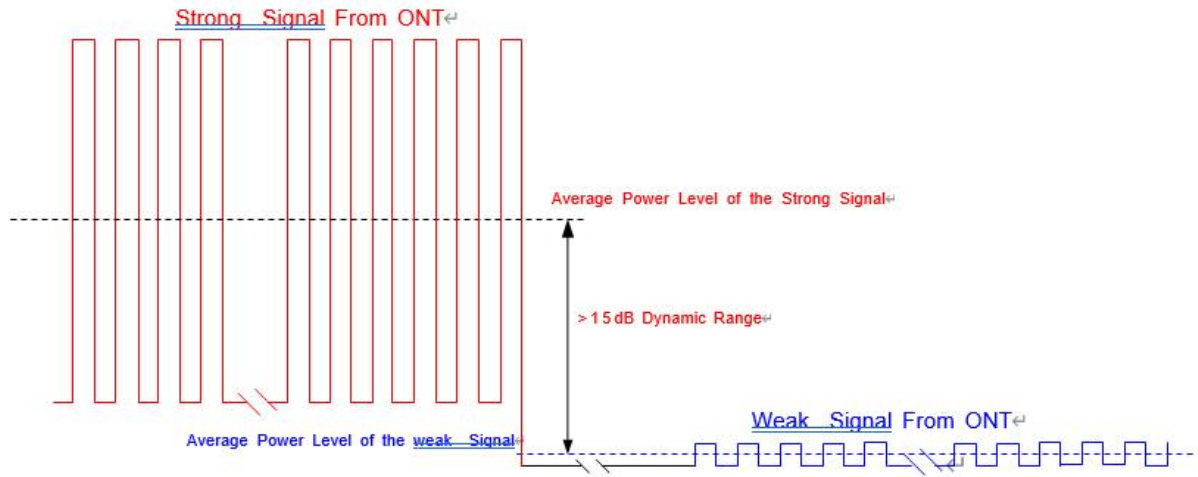

Figure 2 Burst Mode Receiver Dynamic Range in GPON System

Receiver Electrical Characteristics

Table 6- Receiver Electrical Characteristics

Parameter	Symbol	Min.	Typ.	Max.	Unit	Notes
Data Output Voltage – Low		Vcc - 1.81		Vcc - 1.62	V	
Data Output Voltage – High(-Vcc)		Vcc - 1.02		Vcc - 0.88	V	
Data Output Differential Swing		400		1600	mV	LVPECL output, DC coupled
Reset with	TRESET	16			bits	
Reset-Low		0		0.4	V	
Reset- High		2.4		Vcc	V	
Receiver Amplitude Recovery	TRECOVERY			32	bits	Refer to the Reset signal falling
Signal Detect Assert Time				50	ns	
Signal Detect De-assert Time				12.8	ns	Refer to the Reset signal rising
Signal Detect Voltage-Low		0		0.4	V	
Signal Detect Voltage-		2.4		Vcc	V	

High						
RSSI Trigger-Low		0		0.8	V	
RSSI Trigger- High		2.0		Vcc	V	
Optical Signal During Time	Tont	1200			ns	
RSSI Trigger with	TW	500			ns	
RSSI Trigger Delay	TD	150			ns	
I ² C Access Prohibited Time				500	ps	

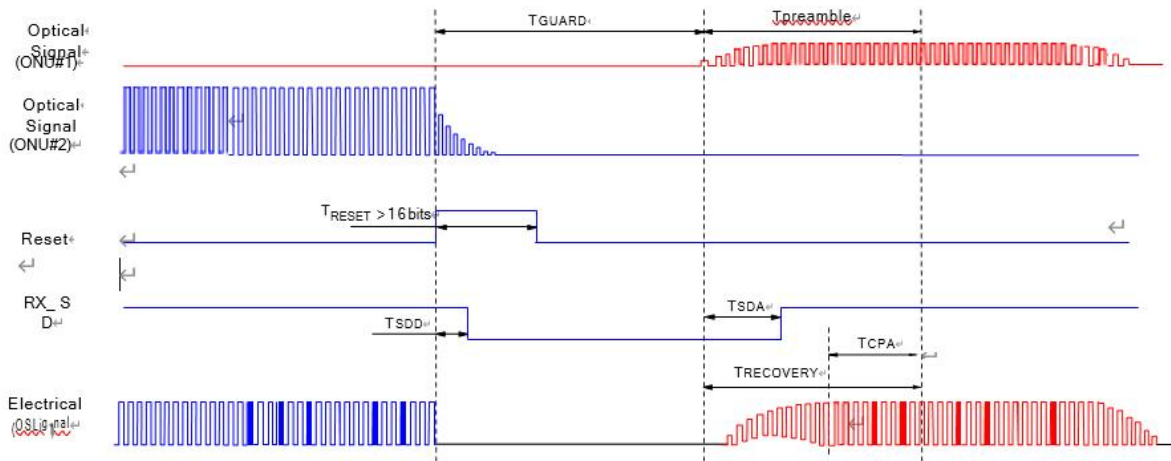

Figure 3 Burst Receiver Timing Sequence

Digital Diagnostic Monitoring

Table 7- Digital Diagnostic Monitoring

Parameter	Range	Accuracy	Calibration	Note
Temperature	0 to +70 °C	±3°C	Internal	1LSB = 1/256°C
Voltage	3.0 to 3.7 V	±3%	Internal	1LSB = 0.1mV
Bias Current	0 to 100 mA	±10%	Internal	1LSB = 2uA
TX Power	1.5 to 5 dBm	±2dB	Internal	1LSB = 0.1uW
RX Power Monitor	-30 to -8 dBm	±3dB	External	1LSB = 0.1uW

Note: The digital diagnostic monitoring interface defines 256-byte memory map in EEPROM, which makes use of the 8 bit address 1010001X(A2h).

RSSI Timing Sequence

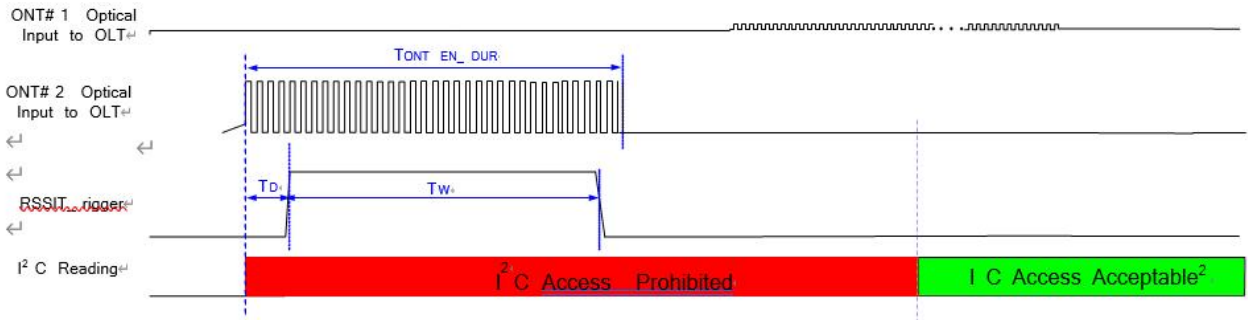

Figure 4 RSSI TIMING SEQUENCE

PIN Description

Table 8- PIN Description

PIN	Name	Description	Notes
1	V EET	Transmitter Ground	
2	TX Fault	Transmitter Fault Indication	High: abnormal; Low : normal
3	TX Disable	Transmitter Disable	High: transmitter disable; Low : transmitter enable
4	MOD-DEF2	Module Definition 2	The data line of two wire serial interface
5	MOD-DEF1	Module Definition 1	The clock line of two wire serial interface
6	MOD-DEF0	Module Definition 0	Connected to Ground in the transceiver
7	Reset	Receiver Reset	High: reset the receiver
8	SD	Signal Detect	High: signal detected; Low loss of signal;
9	RSSI Trigger	RSSI Trigger for Transceiver A/D Conversion	High: enable RSSI A/D conversion
10	V EER	Receiver Ground	
11	V EER	Receiver Ground	
12	RD-	Inv. Receiver Data Out	LVPECL logic output, DC coupled
13	RD+	Receiver Data Out	LVPECL logic output, DC coupled
14	V EER	Received Ground	
15	VCC R	Receiver Power	
16	VCCT	Transmitter Power	

17	V EET	Transmitter Ground	
18	TD+	Transmit Data In	LVPECL logic input, AC coupled
19	TD-	Inv. Transmit Data In	LVPECL logic input, AC coupled
20	V EET	Transmitter Ground	

SFP Recommended Host Board Power Supply Filtering Network

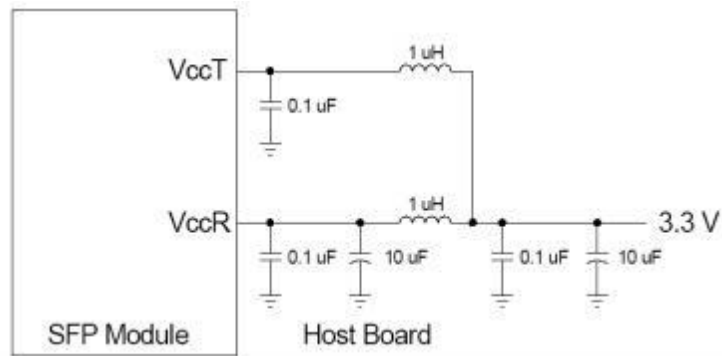

Figure 5 SFP Recommended Host Board Power Supply Filtering Network

SFP Pin (Golden Finger) Drawing

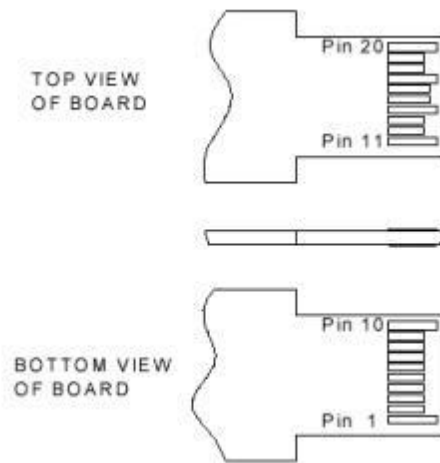

Figure 6 SFP Pin (Golden Finger) Drawing

Typical Interface Circuit

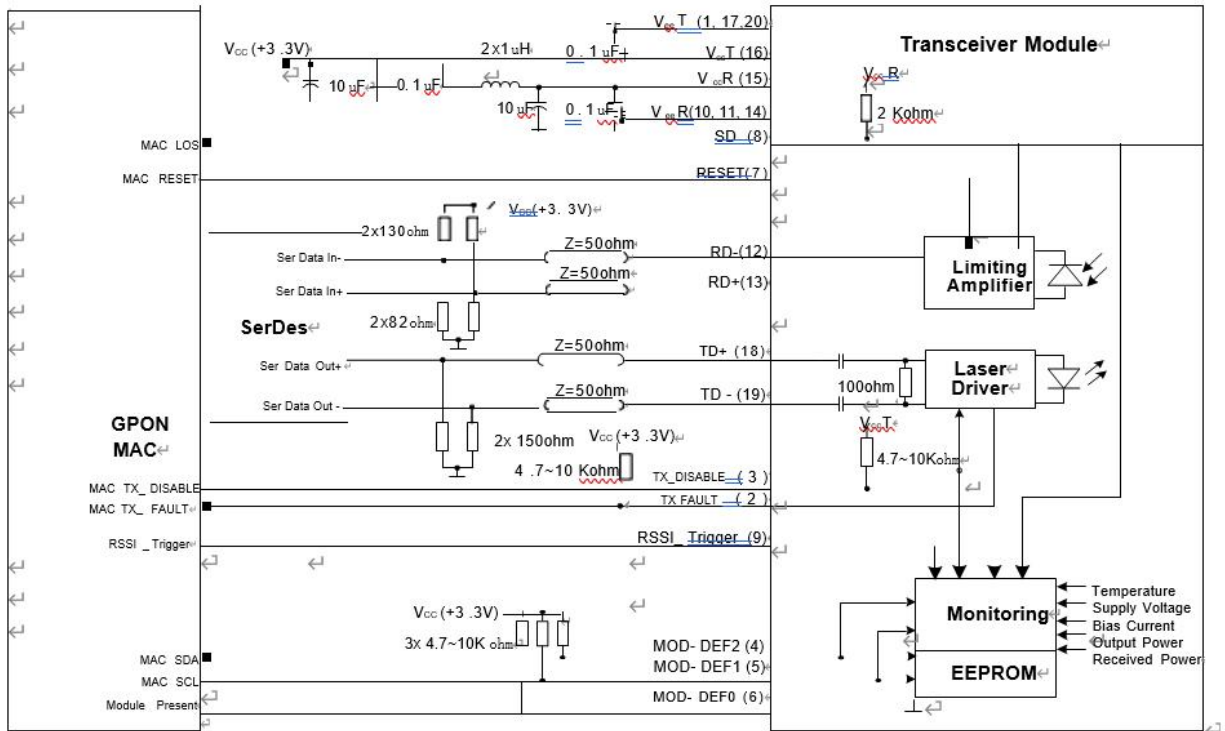
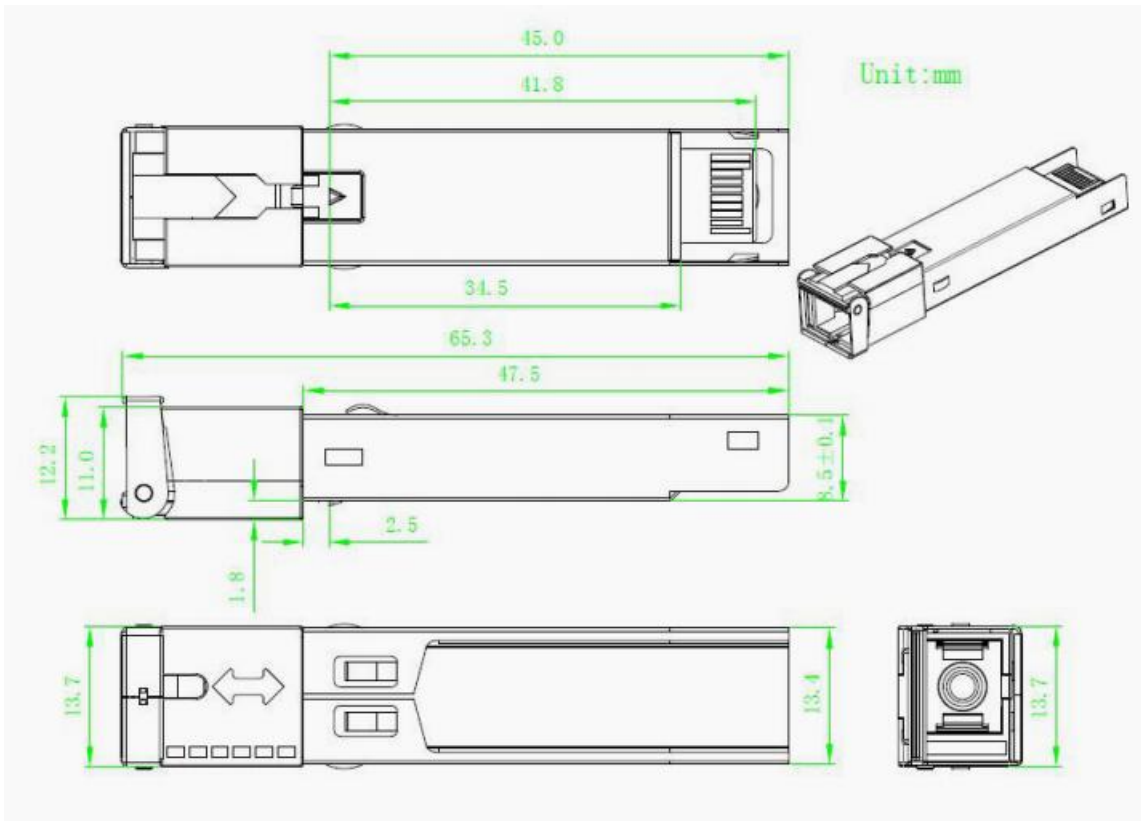

Figure 7 Typical Interface Circuit

Mechanical Specifications



Ordering information

Table 9- Ordering information

Part Number	Product description
VC-GPON-OLT-C+++	SFP, TX 2488Mbps / RX1244Mbps, 1490nm/1310nm, SC/UPC, GPON OLT Class C+++, 0 ~ +70°C, with DDM